

▶ Insert Specifications

Binding Method	Perfect Bound
Book Trim Size	8" x 10 1/2"
Insert Size	Minimum: 4 1/4" width x 5" length Maximum: 8 1/4" width x 10 3/4" length
Live Matter	Keep live matter 1/4" from all trims
Jog Directions	Head
Head Trim	1/8"
Perforations	Must not exceed 60 paper / 40 air Must be at least 1/2" from bind edge
Paper Weight	Minimum: 70# Text Weight Maximum: 80# Text Weight*

*Note: Advertiser may petition for weight exception (up to 105# max.) by sending a stock sample in advance to MSP Communications.

PACKING REQUIREMENTS

- All materials must be accompanied by a detailed packing list and Bill of Lading.
- Each skid and/or carton should be clearly marked, on all four sides, with:
 - Counts per lift/carton
 - Total counts per skid
 - Total number of pieces (forms) for roll stock and/or fanfold
 - Description of piece (Key Code, unique identifier)
 - Title and Issue, or Quad/Graphics job number
- All skids must be secured, wrapped, and banded with plastic banding, not metal.
- The total height of the skid can be no more than 45"; the dimensions must be no more than 48" long by 40" wide, and not less than 46" long by 36" wide.

OTHER REQUIREMENTS

- Blueline proof showing trims, bleeds and perms must be sent to publisher prior to printing.
- MSP Communications must verify print quantity prior to printing.
- Unusual gimmicks, gatefolds, envelopes, die-cuts, etc. must have prior approval before acceptance and may incur additional slowdown charges or other penalties.
- Advertiser/agency bears the responsibility of ensuring that all U.S. Postal Service specs are met, including paper weight, paper thickness, FIM and bar code placement.
- Quantity of supplied inserts should be 3% over the needed quantity.

MULTI-PART SHIPMENTS

For any multi-part shipment, the BOL must clearly state how many separate shipments will make up the total shipment. Example: "Shipment 1 of 3", "Shipment 2 of 3", etc.

QUAD/GRAPHICS JOB NUMBER

All product shipments must be accompanied by Quad/Graphics' six-character "JOB NUMBER" on the BOL. If the Quad/Graphics' job number is not available, the BOL must include the title and issue of the product being delivered.

Insert Mock-ups and Proofs Ship to:

MSP Communications
Attn: Delta Sky Production Manager
220 South 6th Street, Suite 500
Minneapolis, MN 55402-4507

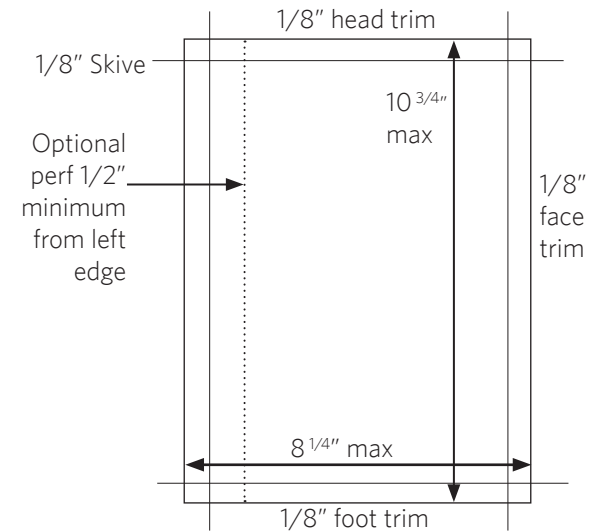

Printed Inserts Ship To:

Quad/Graphics
Attn: Receiving/Job #
1900 W. Summer St
Hartford, WI 53027

Receiving Hours:

7:00 a.m. - 4:00 p.m.
Monday - Friday
All drivers call ahead 24 hours
Phone: 414.566.2898
No shipments accepted on holidays